

A. General

Models 126 can be optionally provided with a newly developed automatic climate control system instead of manual air conditioning.

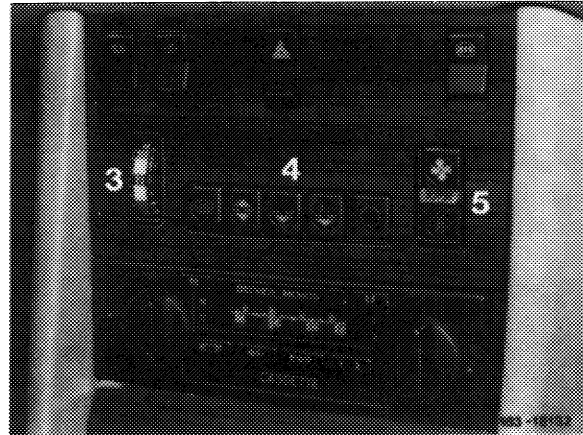

- 3 Temperature dial
- 4 Pushbutton switch with 5 functions
- 5 Blower switch

The automatic climate control system regulates the desired in-car temperature. Heating, cooling and air distribution (top, center, bottom) are automatically controlled.

Automatic climate control operates only when the engine is running.

For adaptation to prevailing weather conditions, the various functions can be selected by means of push-buttons. The air inlets in center of instrument panel and the side vents can be opened, closed or swivelled as desired.

For perfect operation of automatic climate control, the manually operated air inlets should not be closed all together.

Buttons should be pushed only one at a time.

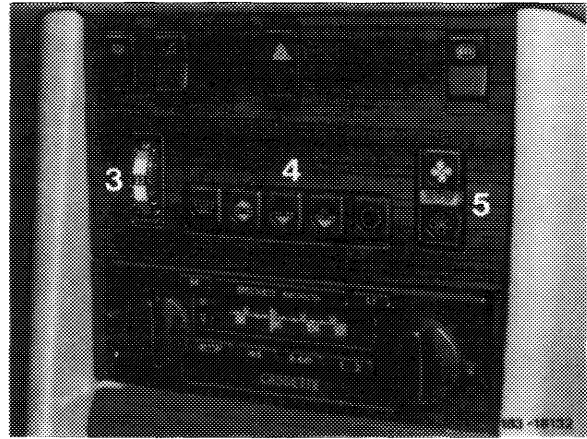

## B. Control unit

The control unit is located in center console and comprises a temperature dial (3), a pushbutton switch unit (4) and blower switch (5).

The temperature dial serves for stepless adjustment of in-car temperature between the two end detent positions "MIN" = not heating and "MAX" = fully heating.

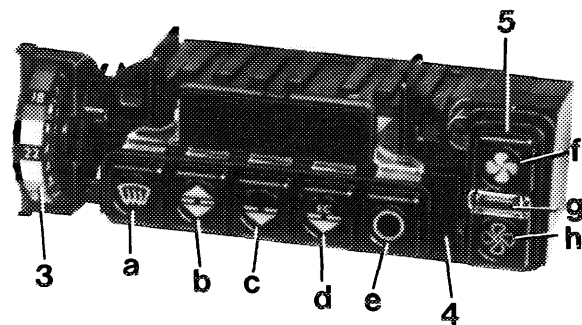

183-17660/1

Set to "MAX" means full, uncontrolled heating capacity; set to "MIN" means full, uncontrolled cooling capacity, each time in 5th blower stage. These functions apply only for pushbuttons "b", "c" and "d", as well as for blower switch in position "AUTOM". The temperature set with temperature dial is attained as quickly as possible and will then remain constant.

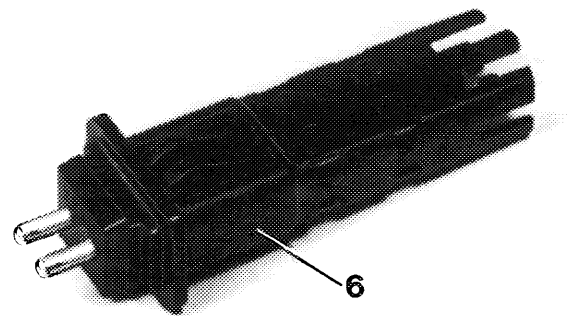

6 Temperature sensor for heat exchanger (up to 12/80)

183-17655

To prevent undesired temperature fluctuations the temperature, once set, should be corrected in small steps only. Rotation of temperature dial will adjust a potentiometer. Together with in-car temperature sensor (7), as well as sensor (6) for heat exchanger, the potentiometer indicates the nominal value for temperature control.

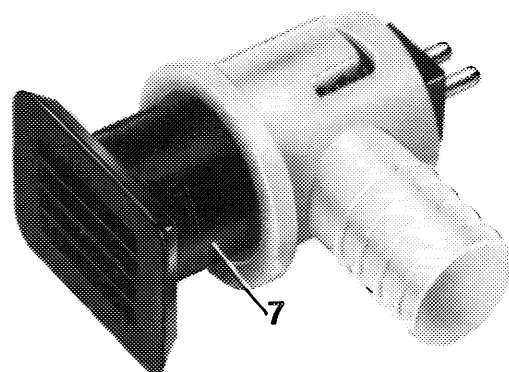

7 In-car temperature sensor (up to 06/81)

183-17657/1

6 Temperature sensor for heat exchanger (starting January 1981)

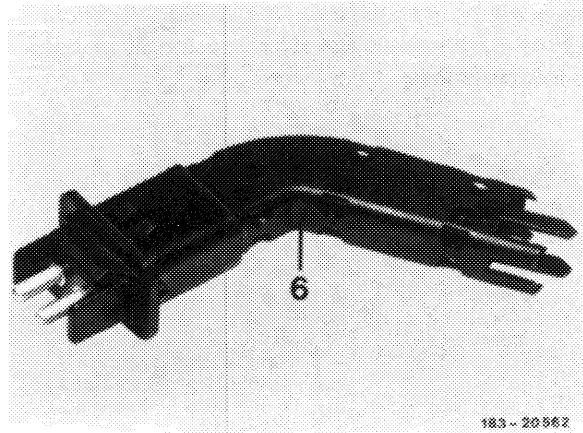

6 Layout temperature sensor for heat exchanger

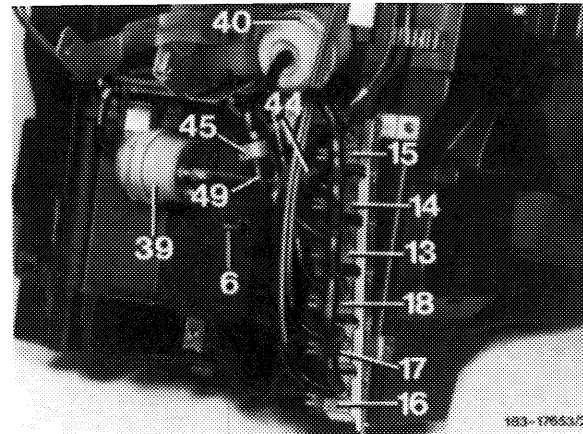

7 In-car temperature sensor (starting July 1981)

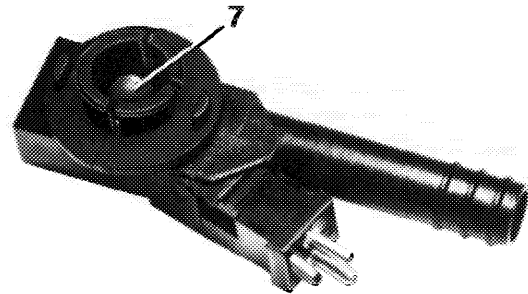

1 Layout in-car temperature sensor (starting July 1981)

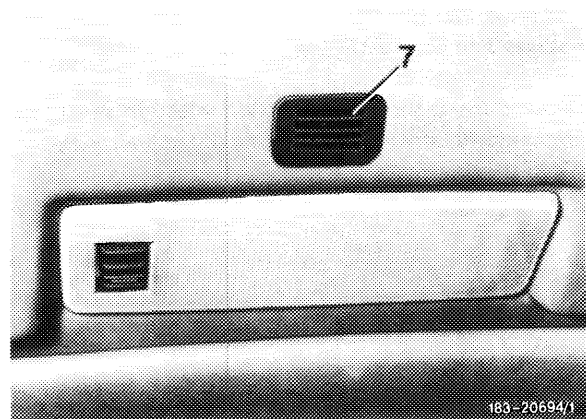

The pushbutton switch unit (4) provides 5 functions (a to e), the blower switch (5) 3 (f, g, h); all are included in control unit.

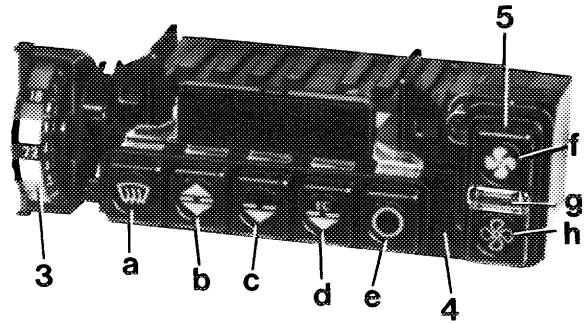

- 3 Temperature dial
- 4 Pushbutton switch unit with 5 functions
- 5 Blower switch

183-17660/1

### Function selection "e" (Off)

Selecting this function will switch off the air supply through main air flap into inside of vehicle, (e.g., in the event of unpleasant outside dust or odors).

The electronic system continues to operate while driving and the monovalve (11) remains closed. Blower is not operating.

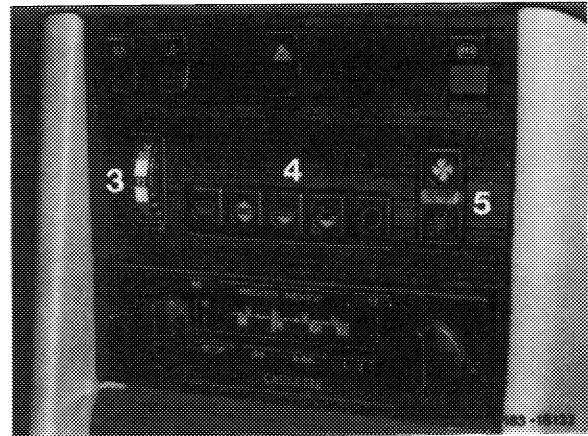

### Function selection "d" (refrigerant compressor off)

EC (ECONOMY): Refrigerant compressor is off. System operates with fresh air only.

In heating range, tempered air will flow out of leg room and side nozzles, with a leak air share from defroster nozzles. The windshield will be provided with just enough air to remain free of fog during normal weather conditions.

In venting range, air is routed to air inlets in center of instrument panel and to lateral vents only. The minimum in-car temperature depends on outside temperature and on solar radiation.

At low outside temperatures, the air supply and the blower remain in off position until the engine is heated to approx. 35 °C by the coolant. The blower operates in stages 3 to 5 at "AUTOM".

We recommend the above function selection at outside temperatures, at which no cooling of fresh air is required (to save fuel).

### Function selection "c" (normal adjustment)

Function selection "c" corresponds to function selection "d", but with a cooling effect.

The refrigerant compressor of the air conditioning system is switched on at outside temperatures above + 4 °C.

If the vehicle in-car temperature is higher by approx. 4 °C than the preselected temperature on temperature dial, the blower will start immediately. At "AUTOM" the blower operates in stages 2 to 5.

In heating range, tempered air will flow out of leg room and side nozzles with a leak air share from defroster nozzles.

In cooling range, cooled air will come out of center and side jets only. The mode changes automatically; overlapping is possible, that is, leg room and center nozzles can be opened simultaneously.

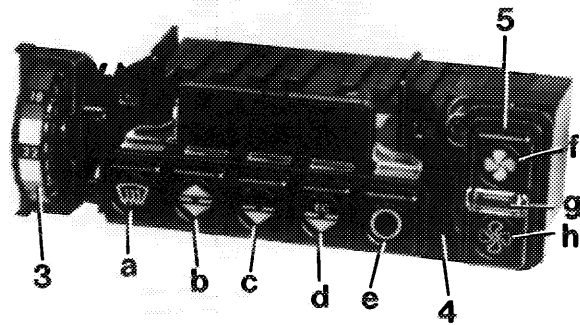

183-17660/1

The compressor is added, the evaporator temperature is held to approx. 0 °C. If the system moves to "full cooling", the main air flap is automatically switched to recirculated air and the scoop air flap will be opened at the same time. Opening of scoop air flap will route a large portion of the air volume from evaporator directly to center and lower side nozzles. Less air will then flow through heat exchanger.

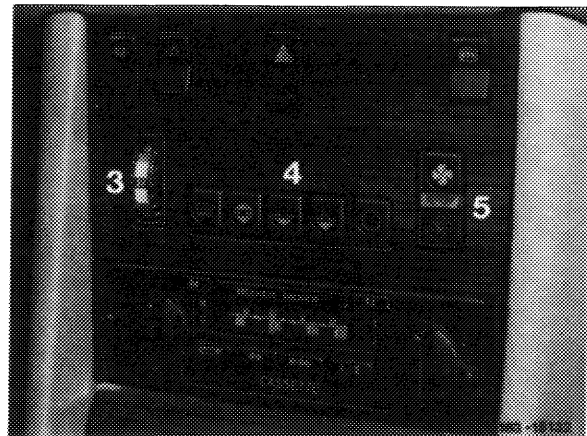

- 3 Temperature dial
- 4 Pushbutton switch unit with 5 functions
- 5 Blower switch with 3 functions

### Function selection "b" top and bottom (overall ventilation)

Blower starts after approx. 10 seconds, also below 35 °C coolant temperature. In position "AUTOM" in stages 3 to 5. Refrigerant compressor is switched on.

In heating range air is routed to windshield, to side vents and to leg room; in cooling range additionally to air inlets in center of instrument panel.

The interior of the vehicle is extensively cooled free of draft, the leg room is cooled more intensively. This function serves the purpose of removing fog, if any, on glass during damp, cold weather conditions.

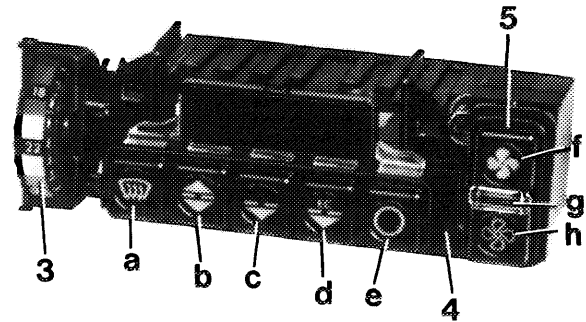

- 3 Temperature dial
- 4 Pushbutton switch unit with 5 functions
- 5 Blower switch with 3 functions

183-17660/1

### Function selection "a" (defrosting)

With the ignition switched on, the blower will start immediately and operates in 6th blower stage only.

Independent of temperature dial adjustment, max. heated air will be routed to windshield.

The recirculating pump is always running along and the refrigerant compressor is switched on. If, with the ignition switched on, function selection "a" or "b" is pushed, followed by switching to "c" or "d", the system remains in operation also below 33 °C coolant temperature.

**Blower switch (5)**

The blower operates in 6 stages.

At function selection "b", "c" and "d", the air volume can be set as required.

Switch	Air volume	Blower stage
f (top)	max.	6 (12 V)
h (bottom)	min.	1 ( 4 V)
g (center)	automatic	2-5 (5-10 V)

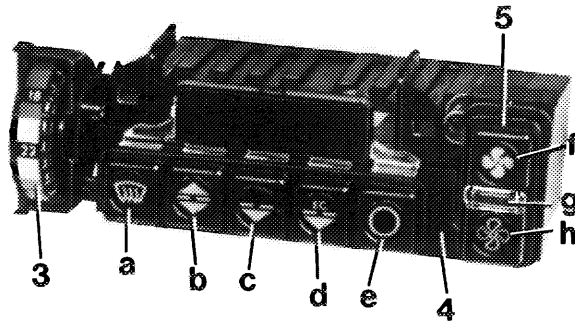

183-17660/1

During "AUTOM" operation in functions "b, c and d" the blower will start in 2nd blower stage after the system has been switched on, with a delay of approx. 10 seconds and remains constant for approx. 10 seconds (on vehicles up to 12/80 approx. 30 seconds). If required, blower switches up to 5th blower stage.

**C. Temperature sensor**

Layout of in-car temperature sensor on instrument panel

- 7 In-car temperature sensor (up to 06/81)

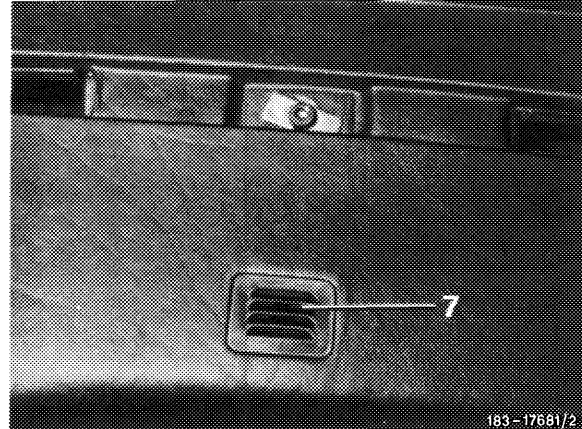

183-17661/2

Layout of in-car temperature sensor in roof frame lining

- 7 In-car temperature sensor (starting 07/81)

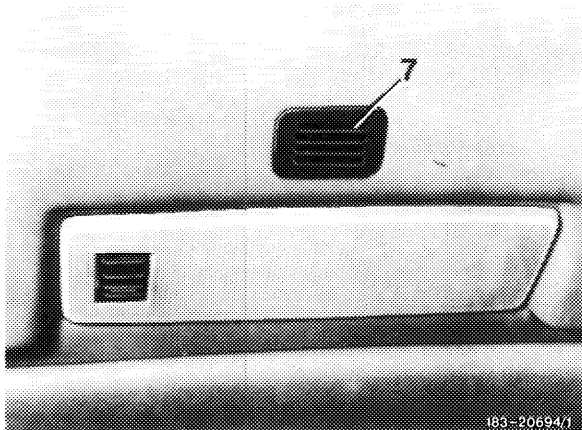

183-20694/1

The in-car temperature sensor (7) is located under a grille at top in instrument panel or at top in roof frame lining. The sensor feels the in-car temperature and transmits that temperature to the electronic switchgear (9) to balance the temperature as set.

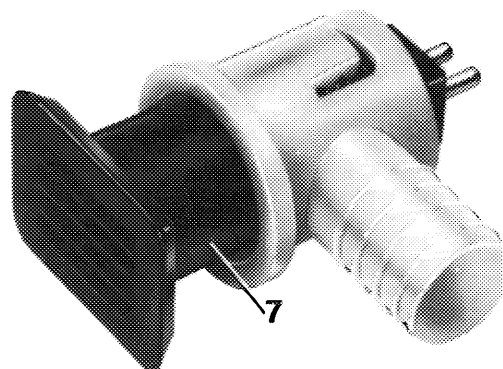

7 In-car temperature sensor (up to 06/81)

183-17657/1

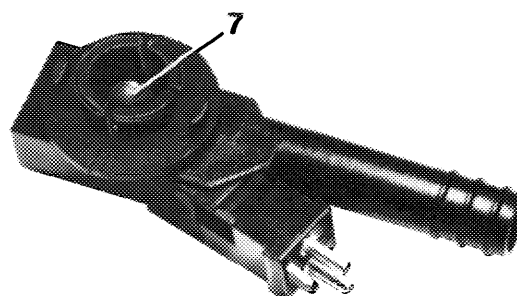

7 In-car temperature sensor (starting 07/81)

183-22100

An air jet (47) attached to blower housing will draw air from interior of vehicle by way of the in-car temperature sensor while the blower is running. As a result, the response period of the sensor is shortened and the control accuracy is increased.

The temperature sensor (6) for heat exchanger is located in housing for heat exchanger and transmits the respective outgoing air temperature from heat exchanger to electronic switchgear.

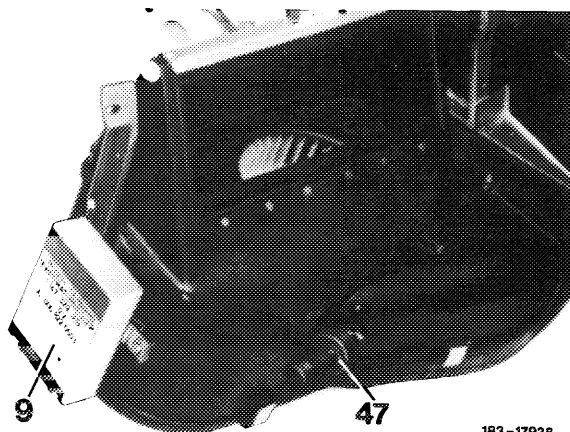

9 Electronic switchgear for temperature control  
47 Air jet

183-17938

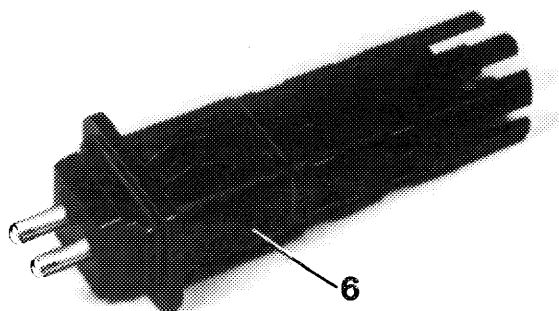

6 Temperature sensor for heat exchanger (up to 12/80)

183-17655

6 Temperature sensor for heat exchanger (starting 01/81)

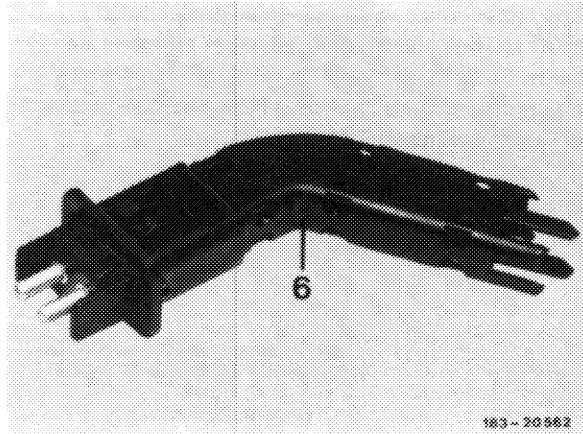

163 - 20 562

Layout of temperature sensor (6) for heat exchanger

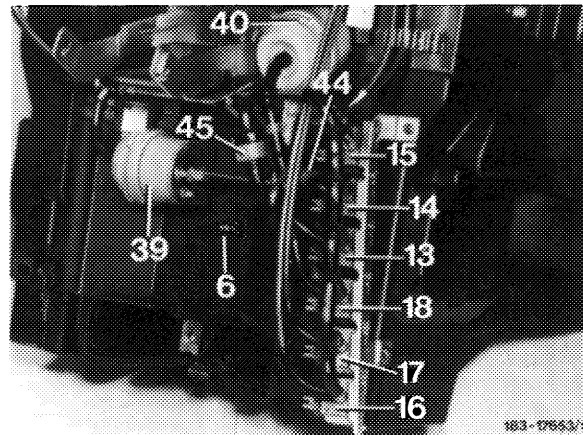

163 - 17663/1

**D. Monovalve with check valve, electric recirculating pump, diagram for coolant circuit and cold engine lock**

Monovalve (11) controls the coolant flow through heat exchanger. The valve comprises a magnetic valve which is continuously connected to plus via terminal 15. Opening and closing times are controlled by electronic switching unit for temperature control via minus. If plus and minus are connected, the valve is closed.

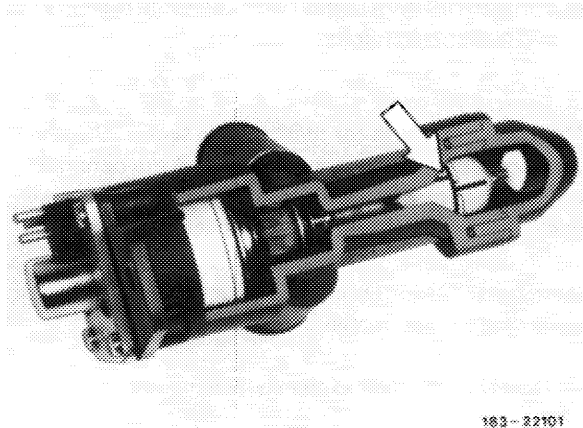

163 - 22101

The opening or closing time depends on the respective deviation from actual to desired temperature.

During controlled operation, the monovalve opens and closes in a 5-second cycle. When the engine is shut off (monovalve "open") the check valve (arrow) installed in monovalve makes sure that the heat exchanger is not filled up with hot coolant.

Layout of monovalve with recirculating pump

- 11 Monovalve
- 30 Recirculating pump

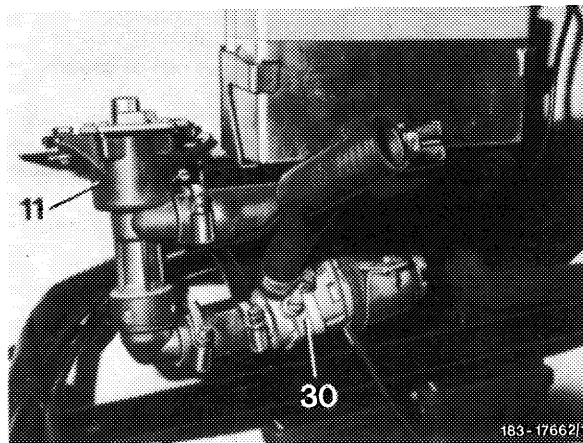

163 - 17662/1

The temperature switch (2) (cold engine lock) prevents starting of system at a coolant temperature below 35°C in functions "c" and "d" and thereby makes sure that no cold air is blown against passengers during the winter.

Layout of temperature switch (cold engine lock) on 8-cylinder models

2 Temperature switch

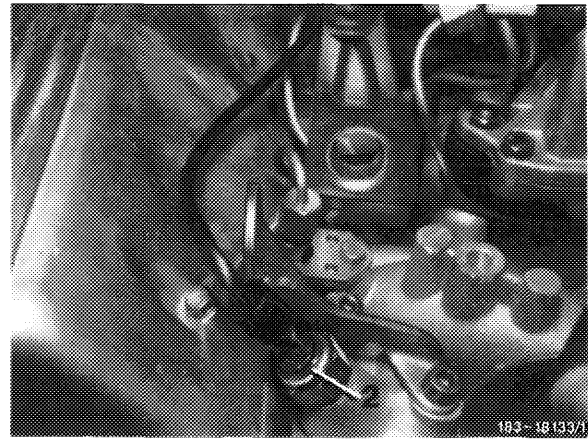

The recirculating pump (30) is located adjacent to monovalve (11) and serves to maintain a uniform coolant flow through heat exchanger (b) also at low engine speeds (Fig.). During controlled operation, the pump is switched on by signal "legroom flaps". Electric activation is by way of control unit.

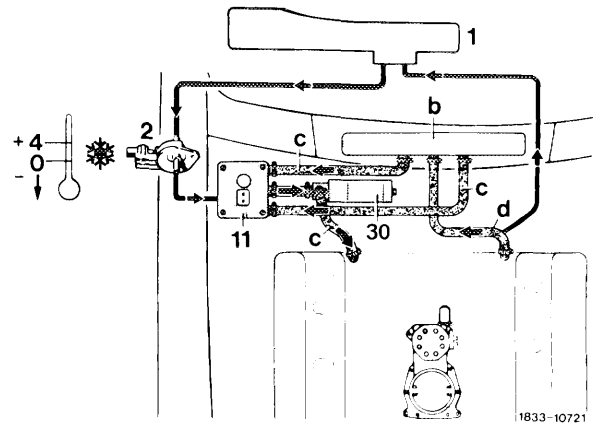

Diagram of coolant circuit

- |                                           |                       |
|-------------------------------------------|-----------------------|
| 1 Surface heat exchanger (starting 11/81) | 11 Monovalve          |
| 2 Thermovalve (starting 11/81)            | 30 Recirculating pump |
|                                           | b Heat exchanger      |
|                                           | c Return flow         |
|                                           | d Forward flow        |

### E. Electronic switchgear for temperature and blower control with electric wiring diagram

The signals of the in-car temperature sensor, the temperature sensor for heat exchanger and the nominal value potentiometer (temperature dial) are processed in electronic switchgear for temperature control.

Switchgear (9) for temperature control regulates according to requirements:

- a) flow through heat exchanger via monovalve,
- b) change of mode, that is, switching from "cooling" to "heating" and vice versa, during which in accordance with pertinent in-car temperature conditions, tempered air may simultaneously come out of leg room nozzles as well as out of center nozzles (overlap).
- c) position of fresh air — recirculating air flap,
- d) control of blower stages via preresistance group (1) by means of switchgear for blower control.



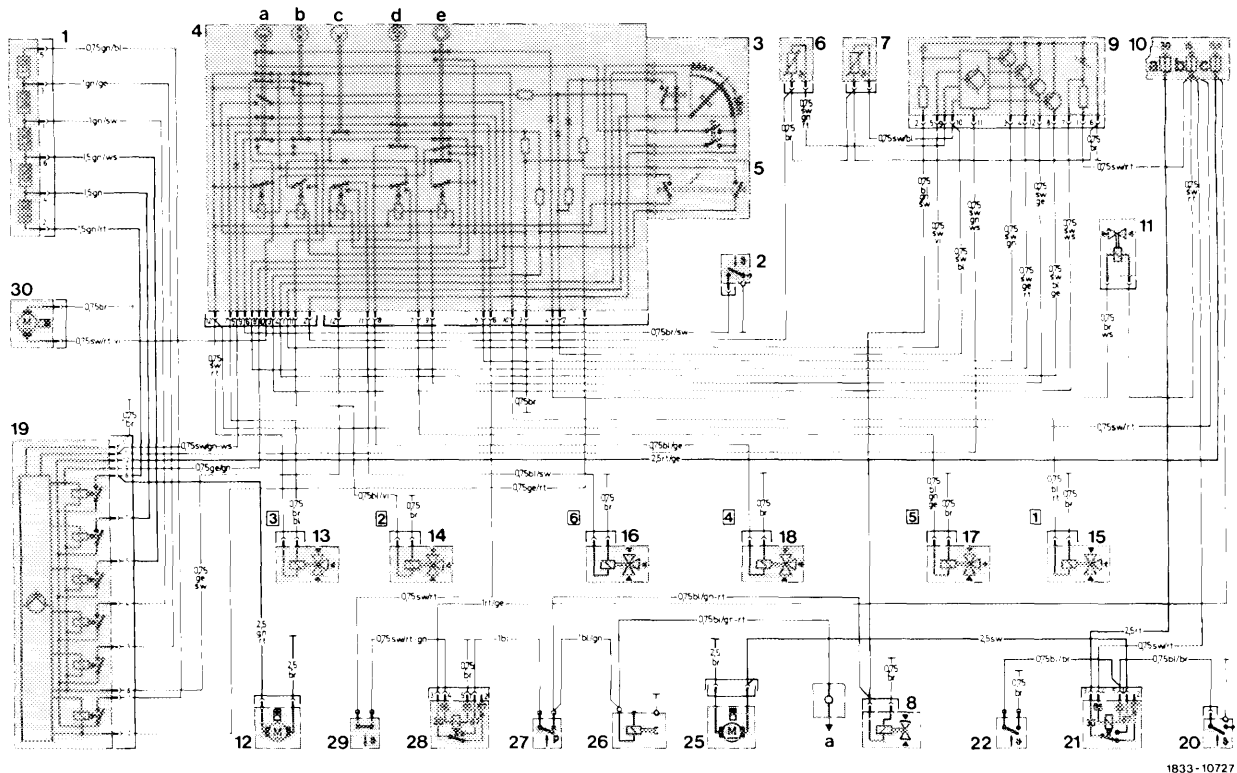

1833-10727

Electric wiring diagram automatic climate control (6-cylinder engine starting 09/81)

- |                                                                                                                                                                                                                                                                                                                                                                                                                                                                                                                                                                                                                                                                                                                                                                                                                                                                                                                                                                                     |                                                                                                                                                                                                                                                                                                                                                                                                                                                                                                                                                                                                                                                                                                                                                                                                    |
|-------------------------------------------------------------------------------------------------------------------------------------------------------------------------------------------------------------------------------------------------------------------------------------------------------------------------------------------------------------------------------------------------------------------------------------------------------------------------------------------------------------------------------------------------------------------------------------------------------------------------------------------------------------------------------------------------------------------------------------------------------------------------------------------------------------------------------------------------------------------------------------------------------------------------------------------------------------------------------------|----------------------------------------------------------------------------------------------------------------------------------------------------------------------------------------------------------------------------------------------------------------------------------------------------------------------------------------------------------------------------------------------------------------------------------------------------------------------------------------------------------------------------------------------------------------------------------------------------------------------------------------------------------------------------------------------------------------------------------------------------------------------------------------------------|
| <ul style="list-style-type: none"> <li>1 Pre-resistor group</li> <li>2 Temperature switch (cold engine lock)</li> <li>3 Temperature dial</li> <li>4 Pushbutton switch unit             <ul style="list-style-type: none"> <li>a Defrosting</li> <li>b Top and bottom</li> <li>c Normal adjustment (air-conditioning system on)</li> <li>d Normal adjustment (air-conditioning system off)</li> <li>e Off</li> </ul> </li> <li>5 Blower switch</li> <li>6 Temperature sensor (heat exchanger)</li> <li>7 In-car temperature sensor</li> <li>8 Switchover valve rpm increase</li> <li>9 Electronic switching unit for temperature control</li> <li>10 Fusebox</li> <li>11 Monovalve</li> <li>12 Blower motor</li> <li>13 Switchover valve for center nozzle flap</li> <li>14 Switchover valve for legroom flaps</li> <li>15 Switchover valve for defroster nozzle flaps</li> <li>16 Switchover valve for fresh air-recirculating air flap and main air flap (small stroke)</li> </ul> | <ul style="list-style-type: none"> <li>17 Switchover valve for fresh air-recirculating air flap and main air flap (large stroke)</li> <li>18 Switchover valve for scoop air flap</li> <li>19 Electronic switching unit for blower control</li> <li>20 Temperature switch 100 °C for auxiliary fan (coolant)</li> <li>21 Relay auxiliary fan</li> <li>22 Temperature switch 52 °C auxiliary fan (refrigerant)</li> <li>25 Auxiliary fan</li> <li>26 Electromagnetic clutch – refrigerant compressor</li> <li>27 Pressure switch refrigerant compressor</li> <li>28 Relay refrigerant compressor</li> <li>29 ETR-switch</li> <li>30 Recirculating pump             <ul style="list-style-type: none"> <li>a Lug main harness, signal refrigerant compressor for decel shutoff</li> </ul> </li> </ul> |
|-------------------------------------------------------------------------------------------------------------------------------------------------------------------------------------------------------------------------------------------------------------------------------------------------------------------------------------------------------------------------------------------------------------------------------------------------------------------------------------------------------------------------------------------------------------------------------------------------------------------------------------------------------------------------------------------------------------------------------------------------------------------------------------------------------------------------------------------------------------------------------------------------------------------------------------------------------------------------------------|----------------------------------------------------------------------------------------------------------------------------------------------------------------------------------------------------------------------------------------------------------------------------------------------------------------------------------------------------------------------------------------------------------------------------------------------------------------------------------------------------------------------------------------------------------------------------------------------------------------------------------------------------------------------------------------------------------------------------------------------------------------------------------------------------|
- Fuses:  
 Fuse a, terminal 30: 16 amps.  
 Fuse b, terminal 15: 8 amps.  
 Fuse c, terminal 15x: 25 amps.

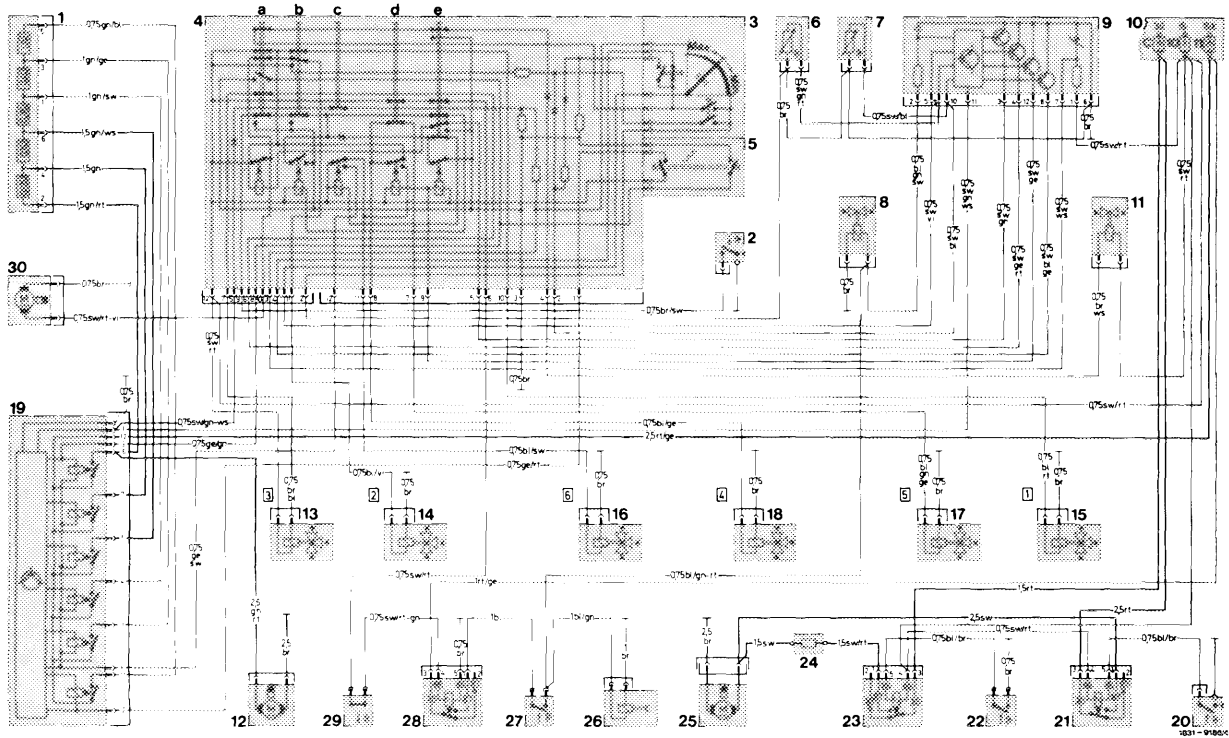

Electric wiring diagram automatic climate control starting August 1980 (USA) (J)

- |                                                                                                                                                                                                                                                                                                                                                                                                                                                                                                                                                                                                                                                                                                                                                                                                                                                                                                                                                                                                 |                                                                                                                                                                                                                                                                                                                                                                                                                                                                                                                                                                                                                                                                                                                                                                                                                                                                                                                                                                            |
|-------------------------------------------------------------------------------------------------------------------------------------------------------------------------------------------------------------------------------------------------------------------------------------------------------------------------------------------------------------------------------------------------------------------------------------------------------------------------------------------------------------------------------------------------------------------------------------------------------------------------------------------------------------------------------------------------------------------------------------------------------------------------------------------------------------------------------------------------------------------------------------------------------------------------------------------------------------------------------------------------|----------------------------------------------------------------------------------------------------------------------------------------------------------------------------------------------------------------------------------------------------------------------------------------------------------------------------------------------------------------------------------------------------------------------------------------------------------------------------------------------------------------------------------------------------------------------------------------------------------------------------------------------------------------------------------------------------------------------------------------------------------------------------------------------------------------------------------------------------------------------------------------------------------------------------------------------------------------------------|
| <ul style="list-style-type: none"> <li>1 Pre-resistor group</li> <li>2 Temperature switch (cold engine lock)</li> <li>3 Temperature dial</li> <li>4 Pushbutton switch unit <ul style="list-style-type: none"> <li>a Defrosting</li> <li>b Overall ventilation</li> <li>c Normal adjustment (air conditioning system on)</li> <li>d EC (air-conditioning system on)</li> <li>e Off</li> </ul> </li> <li>5 Blower switch</li> <li>6 Temperature sensor for heat exchanger</li> <li>7 In-car temperature sensor</li> <li>8 Switchover valve for rpm stabilization (except USA and Japan)</li> <li>9 Electronic switching unit for temperature control</li> <li>10 Fusebox<br/>Starting 8/80 connection relocated from fuse 7 (15 R) to 10, terminal 15 (color code black/red)</li> <li>11 Monovalve</li> <li>12 Blower motor</li> <li>13 Switchover valve for center nozzle flap</li> <li>14 Switchover valve for legroom flaps</li> <li>15 Switchover valve for defroster nozzle flaps</li> </ul> | <ul style="list-style-type: none"> <li>16 Switchover valve for vacuum elements of fresh air-recirculating air flap and main air flap (small stroke)</li> <li>17 Switchover valve for vacuum elements of fresh air-recirculating air flap and main air flap (large stroke)</li> <li>18 Switchover valve for scoop air flap</li> <li>19 Electronic switching unit for blower control</li> <li>20 Temperature switch 100 °C or 110 °C for auxiliary fan (coolant)</li> <li>21 Relay auxiliary fan</li> <li>22 Temperature switch 62 °C for auxiliary fan (receiver dehydrator)</li> <li>23 Relay auxiliary fan (pre-resistor) 8-cylinder engines only</li> <li>24 Pre-resistor auxiliary fan (0.2 Ω) 8-cylinder engines only</li> <li>25 Auxiliary fan</li> <li>26 Electromagnetic clutch-refrigerant compressor</li> <li>27 Pressure switch refrigerant compressor</li> <li>28 Relay refrigerant compressor</li> <li>29 ETR-switch</li> <li>30 Recirculating pump</li> </ul> |
|-------------------------------------------------------------------------------------------------------------------------------------------------------------------------------------------------------------------------------------------------------------------------------------------------------------------------------------------------------------------------------------------------------------------------------------------------------------------------------------------------------------------------------------------------------------------------------------------------------------------------------------------------------------------------------------------------------------------------------------------------------------------------------------------------------------------------------------------------------------------------------------------------------------------------------------------------------------------------------------------------|----------------------------------------------------------------------------------------------------------------------------------------------------------------------------------------------------------------------------------------------------------------------------------------------------------------------------------------------------------------------------------------------------------------------------------------------------------------------------------------------------------------------------------------------------------------------------------------------------------------------------------------------------------------------------------------------------------------------------------------------------------------------------------------------------------------------------------------------------------------------------------------------------------------------------------------------------------------------------|

Since 08/80 the fuse layout (item 10) has been changed. Electronic switching unit (item 9), monovalve (item 11) and relay for auxiliary fan (item 23) are connected to fuse 10, terminal 15. The same applies also to line on terminal 12 of lefthand coupling of control unit (item 4).

As a result, the recirculating pump and the monovalve are not switched on in steering lock position 1. The lines toward fuse 10, terminal 15 are identified a uniform black/red.



Layout electronic switchgear for blower control, vacuum elements for fresh air-recirculated air flap and main air flap

- 19 Electronic switchgear for blower control
- 38 Vacuum element defroster nozzle flaps
- 40 Vacuum element center nozzle flap
- 42 Vacuum element for fresh air-recirculated air flap and main air flap
- 43 Vacuum element for fresh air-recirculated air flap and main air flap

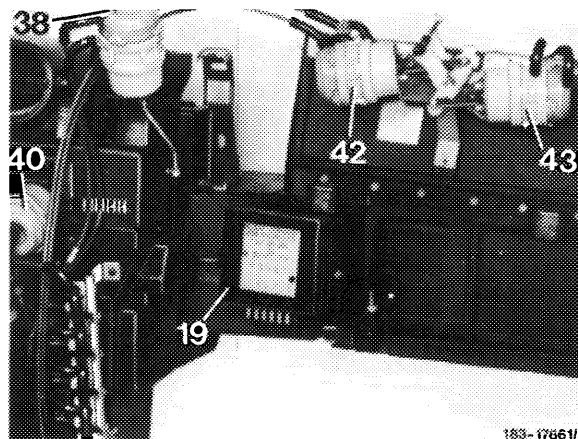

Layout preresistance group for blower under brake booster in unit compartment

- 1 Preresistance group
- 24 Preresistance additional fan (on vehicles with 8-cylinder engines only)

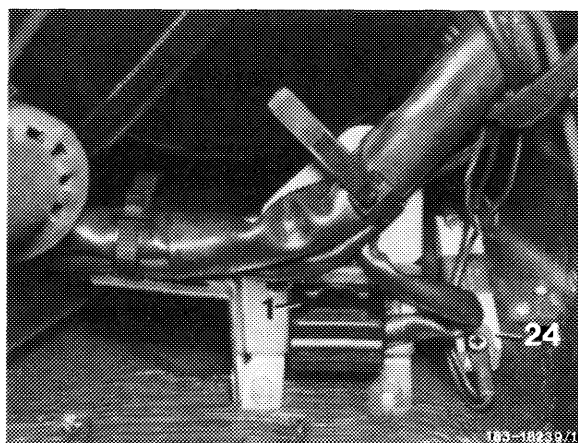

Layout electronic switchgear for temperature control

- 9 Electronic switchgear
- 12 Blower motor
- 47 Air jet

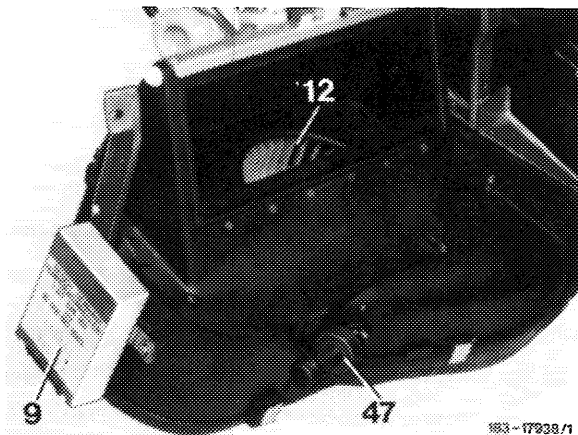

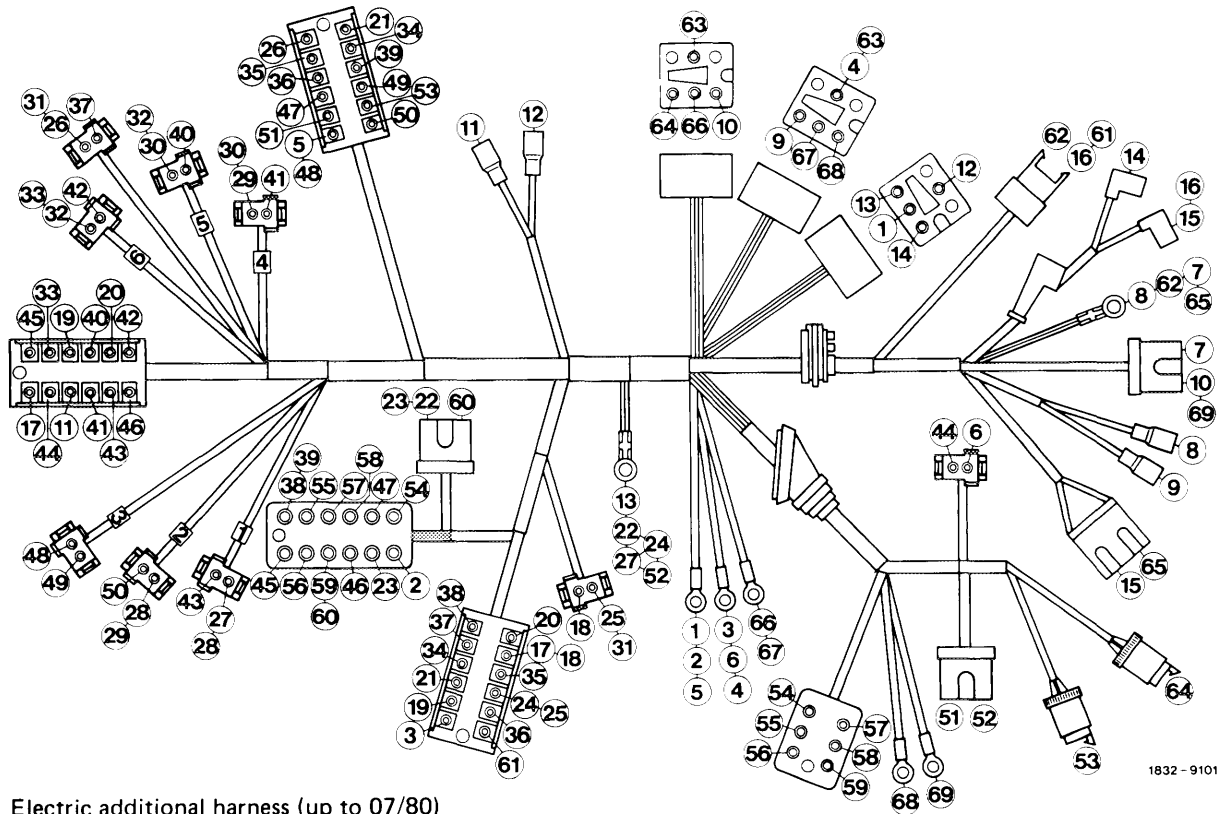

1832 - 9101

Electric additional harness (up to 07/80)

**Color code of supplementary harness**

Line no.	Electric line from	to	Color code	Cross section mm <sup>2</sup>
1	Fuse 11 terminal 15 X	Relay refrigerant compressor terminal 30	red/yellow	1.0
2	Fuse 11 terminal 15 X	Switching unit blower terminal 12	red/yellow	2.5
3	Fuse 7 terminal (15 R) 15	Switching unit temperature control terminal 1	(black/blue/red black/red)	0.75
4	Fuse 7 terminal (15 R) 15	Relay pre-resistor auxiliary fan terminal 86	black/red	0.75
5	Fuse 11 terminal 15 X	Pushbutton switch left terminal 12	red/yellow	0.75
6	Fuse 7 terminal (15 R) 15	Monovalve	(black/red/purple black/red)	0.75
7	Ground	Auxiliary fan	brown	2.5
8	Ground	Temperature switch 52 °C	brown	0.75
9	Temperature switch 52 °C	Relay auxiliary fan pre-resistor terminal 85	blue/brown	0.75
10	Relay fan terminal 87	Auxiliary fan	black	1.5
11	Push button switch right terminal 6	ETR-switch	black/red	0.75
12	ETR-switch	Relay refrigerant compressor terminal 86	black/red/green	0.75
13	Ground	Relay refrigerant compressor terminal 85	brown	0.75
14	Relay refrigerant compressor terminal 87	Pressure switch refrigerant compressor	blue	1.0
15	Pressure switch refrigerant compressor	Refrigerant compressor	blue/green	1.0
16	Pressure switch refrigerant compressor	Rpm increase	blue/green/red	0.75
17	Pushbutton switch right terminal 2	Switching unit temperature control terminal 10	black/blue	0.75

**Color code of additional harness (ctd.)**

Line no.	Electric line from	to	Color code	Cross section mm <sup>2</sup>
18	Switchgear temperature control terminal 10	In-car temperature sensor	black/blue	0.75
19	Switchgear temperature control terminal 3	Pushbutton switch right terminal 5	black/green	0.75
20	Switchgear temperature control terminal 12	Pushbutton switch right terminal 9	black/yellow	0.75
21	Switchgear temperature control terminal 5	Pushbutton switch left terminal 1	black/purple	0.75
22	Ground	Blower motor	brown	2.5
23	Blower motor (ground)	Switchgear blower terminal 10	brown	0.75
24	Ground	Switchgear temperature control terminal 6	brown	0.75
25	Switchgear temperature control terminal 6	In-car temperature sensor	brown	0.75
26	Temperature sensor heat exchanger	Pushbutton switch left terminal 2	brown	0.75
27	Ground	Switchover valve 1	brown	0.75
28	Switchover valve 1	Switchover valve 2	brown	0.75
29	Switchover valve 2	Switchover valve 4	brown	0.75
30	Switchover valve 4	Switchover valve 5	brown	0.75
31	In-car temperature sensor	Temperature sensor heat exchanger	brown	0.75
32	Switchover valve 5	Switchover valve 6	brown	0.75
33	Switchover valve 6	Pushbutton switch right terminal 3	brown	0.75
34	Switchgear temperature control terminal 7	Pushbutton switch left terminal 3	black/white	0.75
35	Switchgear temperature control terminal 8	Pushbutton switch left terminal 4	black/blue/yellow	0.75
36	Switchgear temperature control terminal 4	Pushbutton switch left terminal 6	black/yellow/red	0.75
37	Switchgear temperature control terminal 9	Temperature sensor heat exchanger	black/green/red	0.75
38	Switchgear temperature control terminal 11	Switchgear blower terminal 1	black/green/white	0.75
39	Switchgear blower terminal 1	Pushbutton switch left terminal 5	black/green/white	0.75
40	Pushbutton switch right terminal 7	Switchover valve 5 (position 17)	blue/green/yellow	0.75
41	Pushbutton switch right terminal 8	Switchover valve 4 (position 18)	blue/yellow	0.75
42	Pushbutton switch right terminal 11	Switchover valve 6 (position 16)	blue/black	0.75
43	Pushbutton switch right terminal 10	Switchover valve 1 (position 15)	blue/red	0.75
44	Pushbutton switch right terminal 4	Monovalve	brown/white	0.75
45	Pushbutton switch right terminal 1	Switchgear blower terminal 2	yellow/red	0.75
46	Pushbutton switch right terminal 12	Switchgear blower terminal 8	yellow/black	0.75
47	Pushbutton switch left terminal 8	Switchgear blower terminal 9	yellow/green	0.75
48	Pushbutton switch left terminal 12	Switchover valve 3 (position 13)	black/red	0.75

**Color code of additional harness (ctd.)**

Line no.	Electric line from	to	Color code	Cross section mm <sup>2</sup>
49	Pushbutton switch left terminal 7	Switchover valve 3 (position 13)	brown/blue	0.75
50	Pushbutton switch left terminal 11	Switchover valve 2 (position 14)	blue/purple	0.75
51	Pushbutton switch left terminal 10	Recirculating pump	black/red/purple	0.75
52	Ground	Recirculating pump	brown	0.75
53	Pushbutton switch left terminal 9	Cold engine lock	brown/black	0.75
54	Switchgear blower terminal 11	Resistance group stage 1 terminal 5	green/blue	0.75
55	Switchgear blower terminal 3	Resistance group stage 2 terminal 3	green/yellow	1.0
56	Switchgear blower terminal 4	Resistance group stage 3 terminal 1	green/black	1.0
57	Switchgear blower terminal 5	Resistance group stage 4 terminal 6	green/white	1.5
58	Switchgear blower terminal 7	Resistance group stage 5 terminal 4	green	1.5
59	Switchgear blower terminal 6	Resistance group stage 6 terminal 2	green/red	1.5
60	Switchgear blower terminal 6	Blower motor	green/red	2.5
61	Rpm increase	Switchgear temperature control terminal 2	blue/green/black	0.75
62	Ground	Rpm increase	brown	0.75
63	Relay auxiliary fan pre-resistor terminal 86	Relay auxiliary fan terminal 86	black/red	0.75
64	Temperature switch 100 °C	Relay auxiliary fan terminal 85	blue/brown	0.75
65	Ground	Refrigerant compressor	brown	1.0
66	Terminal 30, fuse C	Relay auxiliary fan terminal 30	red	2.5
67	Terminal 30, fuse C	Relay auxiliary fan pre-resistor terminal 30	red	1.5
68	Relay auxiliary fan pre-resistor terminal 87	Pre-resistor auxiliary fan-input	black/red	1.5
69	Pre-resistor auxiliary fan-output	Auxiliary fan	black	1.5

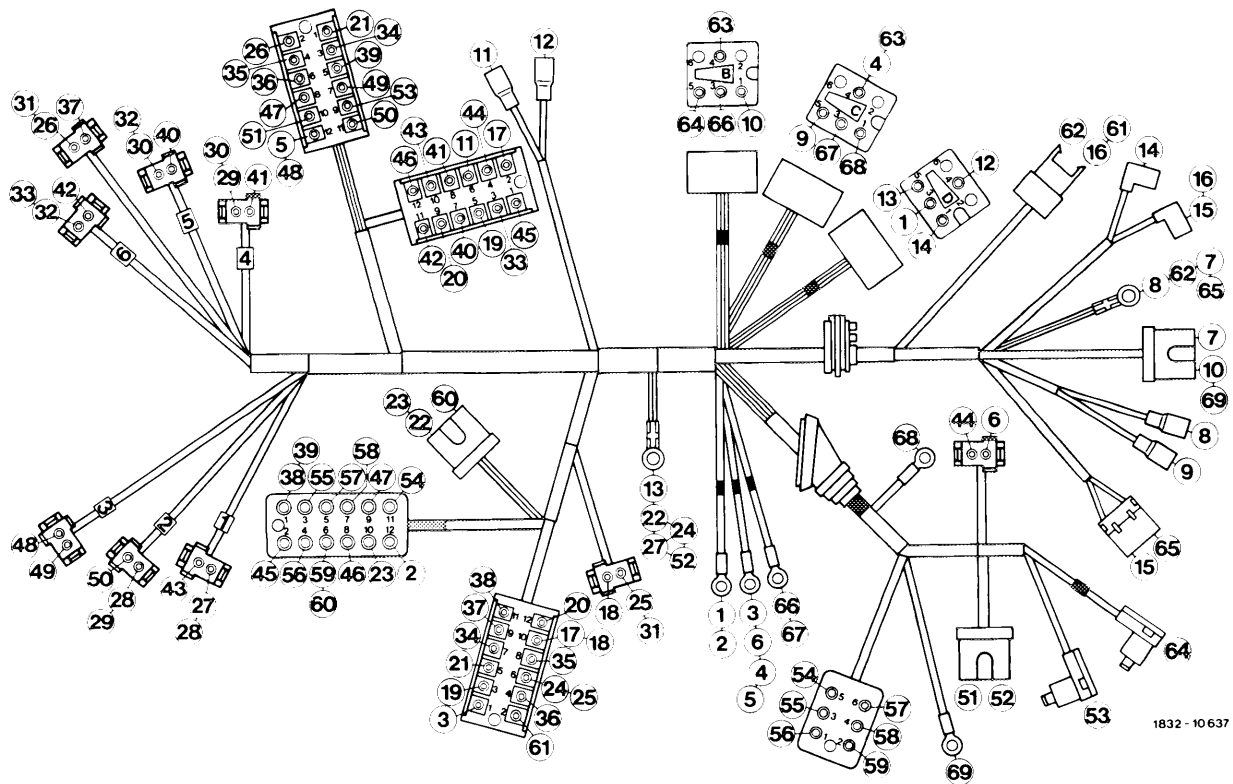

Electric additional harness (starting 08/80 up to 08/81)

**Color code of additional harness**

Line no.	Electric line from	to	Color code	Cross section mm <sup>2</sup>
1	Fuse 11 terminal 15 X	Relay refrigerant compressor terminal 30	red/yellow	1.0
2	Fuse 11 terminal 15 X	Switching unit blower terminal 12	red/yellow	2.5
3	Fuse 10 terminal 15	Switching unit-temperature control terminal 1	black/red	0.75
4	Fuse 10 terminal 15	Relay auxiliary fan pre-resistor terminal 86	black/red	0.75
5	Fuse 10 terminal 15	Pushbutton switch left terminal 12	black/red	0.75
6	Fuse 10 terminal 15	Monovalve	black/red	0.75
7	Ground	Auxiliary fan	brown	2.5
8	Ground	Temperature switch 52 °C (dehydrator)	brown	0.75
9	Temperature switch 52 °C (dehydrator)	Relay auxiliary fan pre-resistor terminal 85	blue/brown	0.75
10	Relay additional fan terminal 87	Auxiliary fan	black	2.5
11	Pushbutton switch right terminal 6	ETR-switch	black/red	0.75
12	ETR-switch	Relay refrigerant compressor terminal 86	black/red/green	0.75
13	Ground	Relay refrigerant compressor terminal 85	brown	0.75
14	Relay refrigerant compressor terminal 87	Pressure switch refrigerant compressor	blue	1.0
15	Pressure switch refrigerant compressor	Refrigerant compressor	blue/green	1.0
16	Pressure switch refrigerant compressor	Rpm increase	blue/green/red	0.75
17	Pushbutton switch right terminal 2	Switching unit temperature control terminal 10	black/blue	0.75

**Color code of additional harness (ctd.)**

Line no.	Electric line from	to	Color code	Cross section mm <sup>2</sup>
18	Switching unit temperature control terminal 10	In-car temperature sensor	black/blue	0.75
19	Switching unit temperature control terminal 3	Pushbutton switch right terminal 5	black/green	0.75
20	Switching unit temperature control terminal 12	Pushbutton switch right terminal 9	black/yellow	0.75
21	Switching unit temperature control terminal 5	Pushbutton switch left terminal 1	black/purple	0.75
22	Ground	Blower motor	brown	2.5
23	Blower motor (ground)	Switching unit blower terminal 10	brown	0.75
24	Ground	Switching unit temperature control terminal 6	brown	0.75
25	Switching unit temperature control terminal 6	In-car temperature sensor	brown	0.75
26	Temperature sensor heat exchanger	Pushbutton switch left terminal 2	brown	0.75
27	Ground	Switchover valve 1	brown	0.75
28	Switchover valve 1	Switchover valve 2	brown	0.75
29	Switchover valve 2	Switchover valve 4	brown	0.75
30	Switchover valve 4	Switchover valve 5	brown	0.75
31	In-car temperature sensor	Temperature sensor heat exchanger	brown	0.75
32	Switchover valve 5	Switchover valve 6	brown	0.75
33	Switchover valve 6	Pushbutton switch right terminal 3	brown	0.75
34	Switching unit temperature control terminal 7	Pushbutton switch left terminal 3	black/white	0.75
35	Switching unit temperature control terminal 8	Pushbutton switch left terminal 4	black/blue/yellow	0.75
36	Switching unit temperature control terminal 4	Pushbutton switch left terminal 6	black/yellow/red	0.75
37	Switching unit temperature control terminal 9	Temperature sensor heat exchanger	black/green/red	0.75
38	Switching unit temperature control terminal 11	Switching unit blower terminal 1	black/green/white	0.75
39	Switching unit blower terminal 1	Pushbutton switch left terminal 5	black/green/white	0.75
40	Pushbutton switch right terminal 7	Switchover valve 5 (position 17)	blue/green/yellow	0.75
41	Pushbutton switch right terminal 8	Switchover valve 4 (position 18)	blue/yellow	0.75
42	Pushbutton switch right terminal 11	Switchover valve 6 (position 16)	blue/black	0.75
43	Pushbutton switch right terminal 10	Switchover valve 1 (position 15)	blue/red	0.75
44	Pushbutton switch right terminal 4	Monovalve	brown/white	0.75
45	Pushbutton switch right terminal 1	Switching unit blower terminal 2	yellow/red	0.75
46	Pushbutton switch right terminal 12	Switching unit blower terminal 8	yellow/black	0.75
47	Pushbutton switch left terminal 8	Switching unit blower terminal 9	yellow/green	0.75
48	Pushbutton switch left terminal 12	Switchover valve 3 (position 13)	black/red	0.75

**Color code of additional harness (ctd.)**

Line no.	Electric line from	to	Color code	Cross section mm <sup>2</sup>
49	Pushbutton switch left terminal 7	Switchover valve 3 (position 13)	brown/blue	0.75
50	Pushbutton switch left terminal 11	Switchover valve 2 (position 14)	blue/purple	0.75
51	Pushbutton switch left terminal 10	Recirculating pump	black/red/purple	0.75
52	Ground	Recirculating pump	brown	0.75
53	Pushbutton switch left terminal 9	Cold engine lock	brown/black	0.75
54	Switching unit blower terminal 11	Resistor group stage 1 terminal 5	green/blue	0.75
55	Switching unit blower terminal 3	Resistor group stage 2 terminal 3	green/yellow	1.0
56	Switching unit blower terminal 4	Resistor group stage 3 terminal 1	green/black	1.0
57	Switching unit blower terminal 5	Resistor group stage 4 terminal 6	green/white	1.5
58	Switching unit blower terminal 7	Resistor group stage 5 terminal 4	green	1.5
59	Switching unit blower terminal 6	Resistor group stage 6 terminal 2	green/red	1.5
60	Switching unit blower terminal 6	Blower motor	green/red	2.5
61	Rpm increase	Switching unit temperature control terminal 2	blue/green/black	0.75
62	Ground	Rpm increase	brown	0.75
63	Relay auxiliary fan pre-resistor terminal 86 (fuse 10)	Relay auxiliary fan terminal 86	black/red	0.75
64	Temperature switch 100 °C	Relay auxiliary fan terminal 85	blue/brown	0.75
65	Ground	Refrigerant compressor	brown	1.0
66	Terminal 30 fuse C	Relay auxiliary fan terminal 30	red	2.5
67	Fuse C, terminal 30	Relay auxiliary fan pre-resistor terminal 30	red	1.5
68	Relay auxiliary fan pre-resistor terminal 87	Pre-resistor auxiliary fan input	black/red	1.5
69	Pre-resistor auxiliary fan output	Auxiliary fan	black	1.5

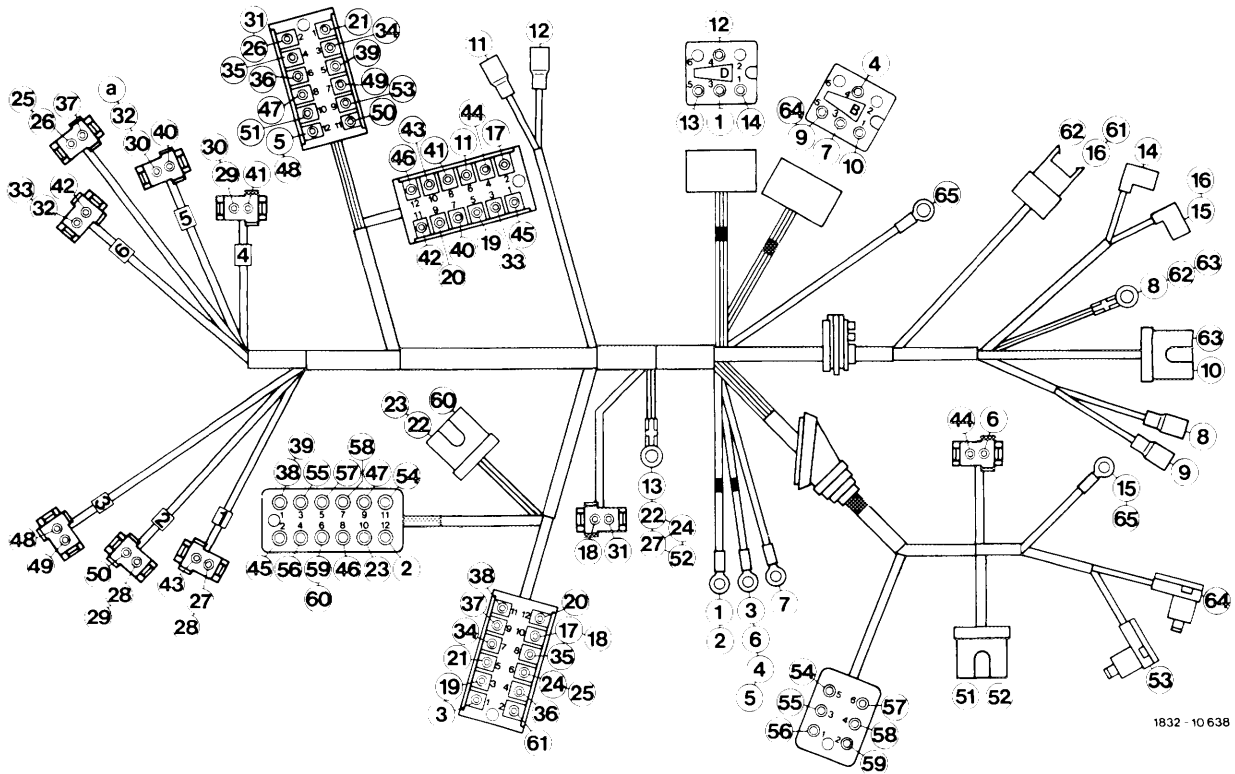

Electric additional harness starting 09/81, engine 110

**Color code of additional harness**

Line no.	Electric line from	to	Color code	Cross section mm <sup>2</sup>
1	Fuse 11 terminal 15 X	Relay refrigerant compressor terminal 30	red/yellow	1.0
2	Fuse 11 terminal 15 X	Switching unit blower terminal 12	red/yellow	2.5
3	Fuse 10 terminal 15	Switching unit temperature control terminal 1	black/red	0.75
4	Fuse 10 terminal 15	Relay auxiliary fan terminal 86	black/red	0.75
5	Fuse 10 terminal 15	Pushbutton switch left terminal 12	black/red	0.75
6	Fuse 10 terminal 15	Monovalve	black/red	0.75
7	Fuse C terminal 30	Relay auxiliary fan terminal 30	red	2.5
8	Ground	Temperature switch 52 °C	brown	0.75
9	Temperature switch 52 °C	Relay auxiliary fan pre-resistor terminal 85	blue/brown	0.75
10	Relay auxiliary fan terminal 87	Auxiliary fan	black	2.5
11	Pushbutton switch right terminal 6	ETR-switch	black/red	0.75
12	ETR-switch	Relay refrigerant compressor terminal 86	black/red/green	0.75
13	Ground	Relay refrigerant compressor terminal 85	brown	0.75
14	Relay refrigerant compressor terminal 87	Pressure switch refrigerant compressor	blue	1.0
15	Pressure switch refrigerant compressor	Refrigerant compressor	blue/green	1.0
16	Pressure switch refrigerant compressor	Rpm increase	blue/green/red	0.75
17	Pushbutton switch right terminal 2	Switching unit temperature control terminal 10	black/blue	0.75

**Color code of additional harness (ctd.)**

Line no.	Electric line from	to	Color code	Cross section mm <sup>2</sup>
18	Switching unit temperature control terminal 10	In-car temperature sensor	black/blue	0.75
19	Switching unit temperature control terminal 3	Pushbutton switch right terminal 5	black/green	0.75
20	Switching unit temperature control terminal 12	Pushbutton switch right terminal 9	black/yellow	0.75
21	Switching unit temperature control terminal 5	Pushbutton switch left terminal 1	black/purple	0.75
22	Ground	Blower motor	brown	2.5
23	Blower motor (ground)	Switching unit blower terminal 10	brown	0.75
24	Ground	Switching unit temperature control terminal 6	brown	0.75
25	Switching unit temperature control terminal 6	Temperature sensor heat exchanger	brown	0.75
26	Temperature sensor heat exchanger	Pushbutton switch left terminal 2	brown	0.75
27	Ground	Switchover valve 1	brown	0.75
28	Switchover valve 1	Switchover valve 2	brown	0.75
29	Switchover valve 2	Switchover valve 4	brown	0.75
30	Switchover valve 4	Switchover valve 5	brown	0.75
31	In car temperature sensor	Pushbutton switch left terminal 2	brown	0.75
32	Switchover valve 5	Switchover valve 6	brown	0.75
33	Switchover valve 6	Pushbutton switch right terminal 3	brown	0.75
34	Switching unit temperature control terminal 7	Pushbutton switch left terminal 3	black/white	0.75
35	Switching unit temperature control terminal 8	Pushbutton switch left terminal 4	black/blue/yellow	0.75
36	Switching unit temperature control terminal 4	Pushbutton switch left terminal 6	black/yellow/red	0.75
37	Switching unit temperature control terminal 9	Temperature sensor heat exchanger	black/green/red	0.75
38	Switching unit temperature control terminal 11	Switching unit blower terminal 1	black/green/white	0.75
39	Switching unit blower terminal 1	Pushbutton switch left terminal 5	black/green/white	0.75
40	Pushbutton switch right terminal 7	Switchover valve (position 17)	blue/green/yellow	0.75
41	Pushbutton switch right terminal 8	Switchover valve 4 (position 18)	blue/yellow	0.75
42	Pushbutton switch right terminal 11	Switchover valve 6 (position 16)	blue/black	0.75
43	Pushbutton switch right terminal 10	Switchover valve 1 (position 15)	blue/red	0.75
44	Pushbutton switch right terminal 4	Monovalve	brown/white	0.75
45	Pushbutton switch right terminal 1	Switching unit blower terminal 2	yellow/red	0.75
46	Pushbutton switch right terminal 12	Switching unit blower terminal 8	yellow/black	0.75
47	Pushbutton switch left terminal 8	Switching unit blower terminal 9	yellow/green	0.75
48	Pushbutton switch left terminal 12	Switchover valve 3 (position 13)	black/red	0.75

**Color code of additional harness (ctd.)**

Line no.	Electric line from	to	Color code	Cross section mm <sup>2</sup>
49	Pushbutton switch left terminal 7	Switchover valve 3 (position 13)	brown/blue	0.75
50	Pushbutton switch left terminal 11	Switchover valve 2 (position 14)	blue/purple	0.75
51	Pushbutton switch left terminal 10	Recirculating pump	black/red/purple	0.75
52	Ground	Recirculating pump	brown	0.75
53	Pushbutton switch left terminal 9	Cold engine lock	brown/black	0.75
54	Switching unit blower terminal 11	Resistance group stage 1 terminal 5	green/blue	0.75
55	Switching unit blower terminal 3	Resistance group stage 2 terminal 3	green/yellow	1.0
56	Switching unit blower terminal 4	Resistance group stage 3 terminal 1	green/black	1.0
57	Switching unit blower terminal 5	Resistance group stage 4 terminal 6	green/white	1.5
58	Switching unit blower terminal 7	Resistance group stage 5 terminal 4	green	1.5
59	Switching unit blower terminal 6	Resistance group stage 6 terminal 2	green/red	1.5
60	Switching unit blower terminal 6	Blower motor	green/red	2.5
61	Rpm increase	Switching unit temperature control terminal 2	blue/green/black	0.75
62	Ground	Rpm increase	brown	0.75
63	Ground	Auxiliary fan	brown	2.5
64	Temperature switch 100 °C	Relay auxiliary fan terminal 85	blue/brown	0.75
65	Refrigerant compressor	Signal refrigerant compressor for idle speed regulation	blue/gray/red	0.75

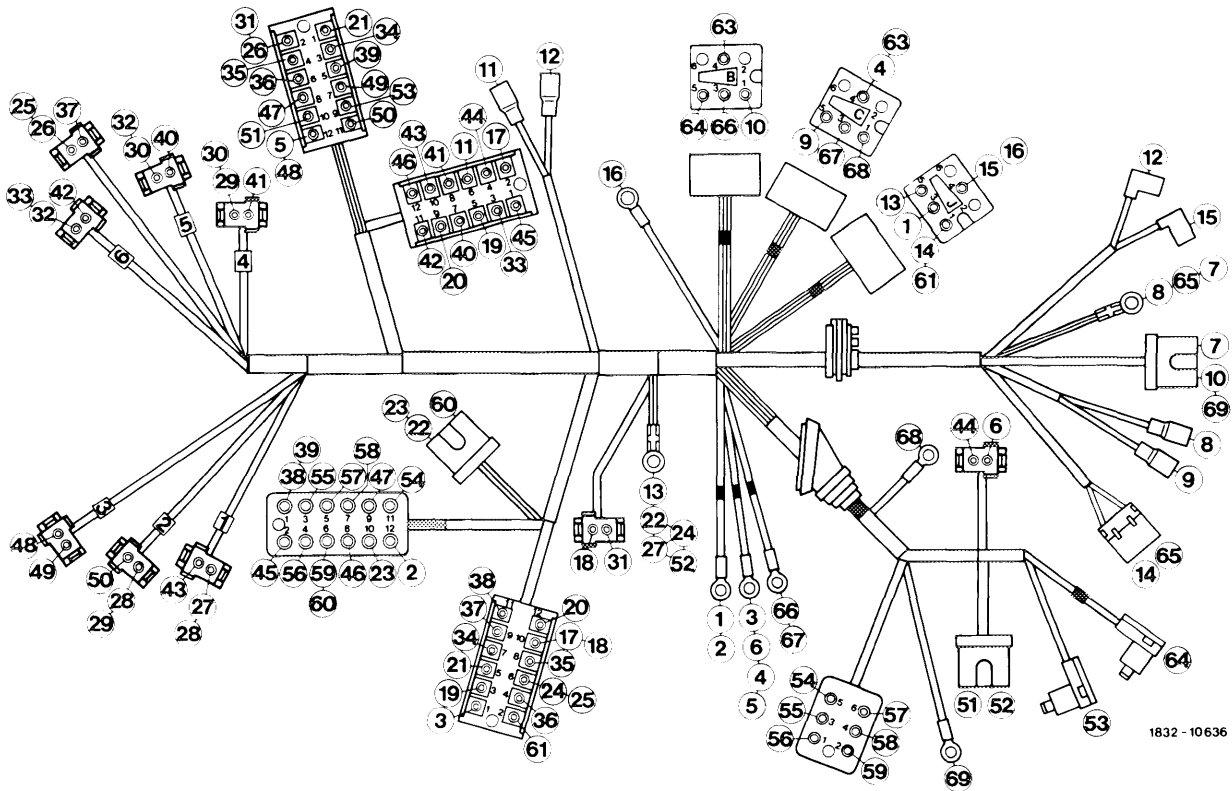

1832-10636

Electric additional harness  
Starting 09/81 engine 116, 117

**Color code of additional harness**

Line no.	Electric line from	to	Color code	Cross section mm <sup>2</sup>
1	Fuse 11 terminal 15 X	Relay refrigerant compressor terminal 30	red/yellow	1.0
2	Fuse 11 terminal 15 X	Switching unit blower terminal 12	red/yellow	2.5
3	Fuse 10 terminal 15	Switching unit temperature control terminal 1	black/red	0.75
4	Fuse 10 terminal 15	Relay auxiliary fan pre-resistor terminal 86	black/red	0.75
5	Fuse 10 terminal 15	Pushbutton switch left terminal 12	black/red	0.75
6	Fuse 10 terminal 15	Monovalve	black/red	0.75
7	Ground	Auxiliary fan	brown	2.5
8	Ground	Temperature switch 52 °C	brown	0.75
9	Temperature switch 52 °C	Relay auxiliary fan pre-resistor terminal 85	blue/brown	0.75
10	Relay auxiliary fan terminal 87	Auxiliary fan	black	2.5
11	Pushbutton switch right terminal 6	ETR-switch	black/red	0.75
12	ETR-switch	Pushbutton switch refrigerant compressor	black/red/green	0.75
13	Ground	Relay refrigerant compressor terminal 85	brown	0.75
14	Relay refrigerant compressor terminal 87	Magnetic clutch refrigerant compressor	blue	1.0
15	Pressure switch refrigerant compressor	Relay refrigerant compressor terminal 86	black/red	0.75
16	Signal refrigerant compressor for idle speed regulation	Relay refrigerant compressor terminal 86	blue/green/red	0.75
17	Pushbutton switch right terminal 2	Switching unit temperature control	black/blue	0.75
18	Switching unit temperature control terminal 10	In-car temperature sensor	black/blue	0.75
19	Switching unit temperature control terminal 3	Pushbutton switch right terminal 5	black/green	0.75

**Color code of additional harness (ctd.)**

Line no.	Electric line from	to	Color code	Cross section mm <sup>2</sup>
20	Switching unit temperature control terminal 12	Pushbutton switch right terminal 9	black/yellow	0.75
21	Switching unit temperature control terminal 5	Pushbutton switch left terminal 1	black/purple	0.75
22	Ground	Blower motor	brown	2.5
23	Blower motor (ground)	Switching unit blower terminal 10	brown	0.75
24	Ground	Switching unit temperature control terminal 6	brown	0.75
25	Switching unit temperature control terminal 6	Temperature sensor heat exchanger	brown	0.75
26	Temperature sensor heat exchanger	Pushbutton switch left terminal 2	brown	0.75
27	Ground	Switchover valve 1	brown	0.75
28	Switchover valve 1	Switchover valve 2	brown	0.75
29	Switchover valve 2	Switchover valve 4	brown	0.75
30	Switchover valve 4	Switchover valve 5	brown	0.75
31	In-car temperature sensor	Pushbutton switch left terminal 2	brown	0.75
32	Switchover valve 5	Switchover valve 6	brown	0.75
33	Switchover valve 6	Pushbutton switch right terminal 3	brown	0.75
34	Switching unit temperature control terminal 7	Pushbutton switch left terminal 3	black/white	0.75
35	Switching unit temperature control terminal 8	Pushbutton switch left terminal 4	black/blue/yellow	0.75
36	Switching unit temperature control terminal 4	Pushbutton switch left terminal 6	black/yellow/red	0.75
37	Switching unit temperature control terminal 9	Temperature sensor heat exchanger	black/green/red	0.75
38	Switching unit temperature control terminal 11	Switching unit blower terminal 1	black/green/white	0.75
39	Switching unit blower terminal 1	Pushbutton switch left terminal 5	black/green/white	0.75
40	Pushbutton switch right terminal 7	Switchover valve 5 (position 17)	blue/green/yellow	0.75
41	Pushbutton switch right terminal 8	Switchover valve 4 (position 18)	blue/yellow	0.75
42	Pushbutton switch right terminal 11	Switchover valve 6 (position 16)	blue/black	0.75
43	Pushbutton switch right terminal 10	Switchover valve 1	blue/red	0.75
44	Pushbutton switch right terminal 4	Monovalve	brown/white	0.75
45	Pushbutton switch right terminal 1	Switching unit blower terminal 2	yellow/red	0.75
46	Pushbutton switch right terminal 12	Switching unit blower terminal 8	yellow/black	0.75
47	Pushbutton switch left terminal 8	Switching unit blower terminal 9	yellow/green	0.75
48	Pushbutton switch left terminal 12 (fuse 10)	Switchover valve 3	black/red	0.75
49	Pushbutton switch left terminal 7	Switchover valve 3	brown/blue	0.75
50	Pushbutton switch left terminal 11	Switchover valve 2	blue/purple	0.75
51	Pushbutton switch left terminal 10	Recirculation pump	black/red/purple	0.75
52	Ground	Recirculation pump	brown	0.75
53	Pushbutton switch left terminal 9	Cold engine lock	brown/black	0.75
54	Switching unit blower terminal 11	Resistor group stage 1 terminal 5	green/blue	0.75
55	Switching unit blower terminal 3	Resistor group stage 2 terminal 3	green/yellow	1.0
56	Switching unit blower terminal 4	Resistor group stage 3 terminal 1	green/black	1.0

**Color code of additional harness (ctd.)**

Line No.	Electric line from	to	Color code	Cross section mm <sup>2</sup>
57	Switching unit blower terminal 5	Resistor group stage 4 terminal 6	green/white	1.5
58	Switching unit blower terminal 7	Resistor group stage 5 terminal 4	green	1.5
59	Switching unit blower terminal 6	Resistor group stage 6 terminal 2	green/red	1.5
60	Switching unit blower terminal 6	Blower motor	green/red	2.5
61	Relay refrigerant compressor terminal 87	Switching unit temperature control terminal 2	blue/green/black	0.75
63	Relay auxiliary fan pre-resistor terminal 86 (fuse 10)	Relay auxiliary fan terminal 86	black/red	0.75
64	Temperature switch 100 °C	Relay auxiliary fan terminal 85	blue/brown	0.75
65	Ground	Refrigerant compressor	brown	1.0
66	Fuse C, terminal 30	Relay auxiliary fan terminal 30	red	2.5
67	Fuse C, terminal 30	Relay auxiliary fan pre-resistor terminal 30	red	1.5
68	Relay auxiliary fan pre-resistor terminal 87	Pre-resistor auxiliary fan input	black/red	1.5
69	Pre-resistor auxiliary fan output	Auxiliary fan	black	1.5

## F. Air path and control of air flaps with vacuum function diagram

The fresh air inlet is located concealed in center in front of windshield (keep free of snow). This will also reduce the influence of the dynamic air pressure as compared with model 116.

Layout of air intake with grille

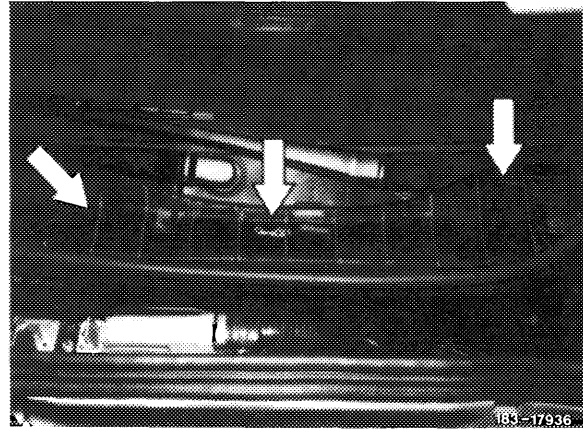

The spent air from inside vehicle is routed through openings in hat rack and through ducts in trunk, as a result of which the latter will be vented and kept cooler in summer and warmer in winter. Ventilation is through openings with check valves at the left and right laterally in trunk, covered by bumper. This range — between bumper and body — is subject to a low vacuum. The design of the venting system guarantees that there is considerably less underpressure inside vehicle at high driving speeds than in model 116.

Layout of venting system with check valves (air outlet).

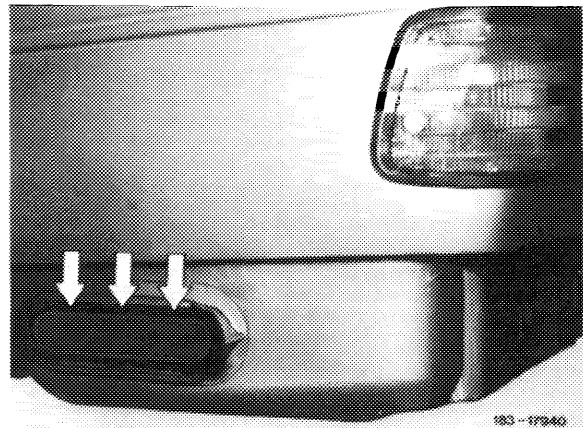

The following illustrations show how the individual air outlets are handled on instrument panel, as well as the air flow out of the heater box to the respective air outlets. With the exceptions of the air outlet for rear passenger compartment, the air from the remaining air outlets (a to e) can be tempered as required.

Layout of swivel inserts for air outlet-center

- 51 Lever for air outlet right (55)
- 52 Swivel inserts for air outlet-center
- 53 Lever for air outlet left (55)
- 54 Lever for center air outlet (52)

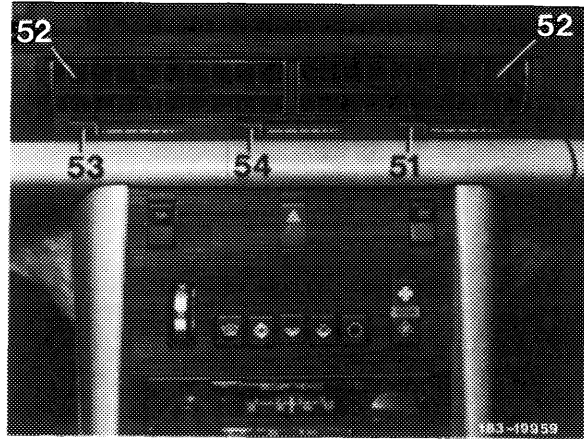

Layout of air outlets right, (mirror image for left)

- 55 Swivel insert for air outlets right
- 56 Insert for side vent right — turn wheel in upward direction = open

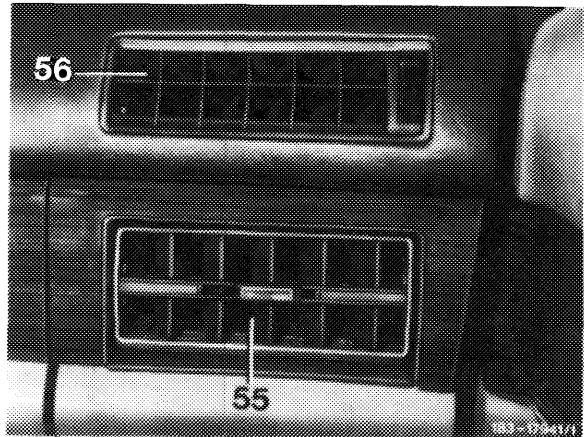

For rear passenger compartment the swivel insert on console for non-heatable fresh air can be additionally opened or closed as required.

Lever to the left = "open" (Fig.).

Ventilation for rear passenger compartment

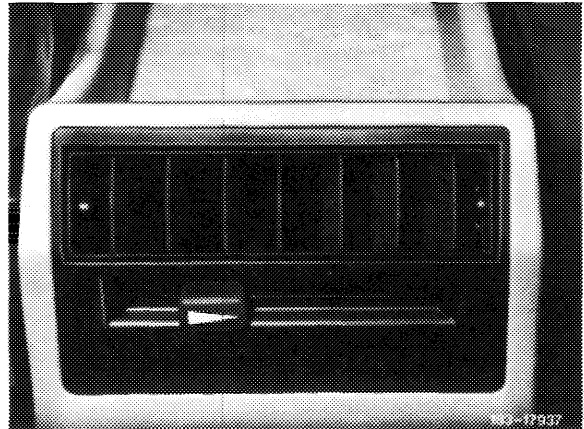

- a Air outlet for defroster nozzle
- b Air outlet for leg and door heater
- c Air outlet for side vent right
- d Air outlet for air nozzle right
- e Air outlet for air nozzle center
- f Air outlet for nozzle rear passenger compartment vent (fresh air only)

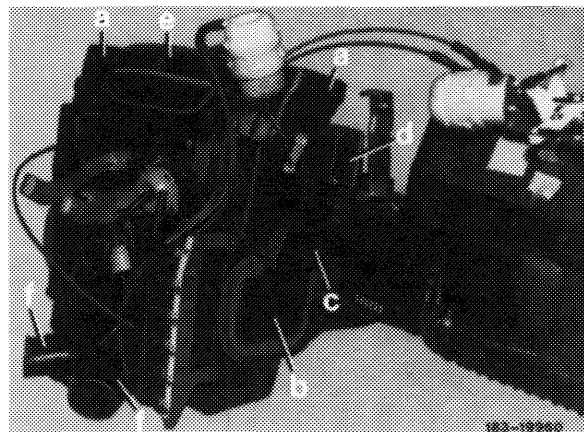

Layout of electric switchover valves

- 6 Temperature sensor for heat exchanger
- 13 Switchover valve for center nozzle flap
- 14 Switchover valve for leg room flap
- 15 Switchover valve for defroster nozzle flaps
- 16 Switchover valve for vacuum elements of fresh air-recirculated air flap and main air flap (small stroke)
- 17 Switchover valve for vacuum elements of fresh air-recirculated air flap and main air flap (large stroke)
- 18 Switchover valve for scoop air flap
- 39 Vacuum element leg room flaps
- 40 Vacuum element center nozzle flap
- 44 Orifice
- 45 Check valve

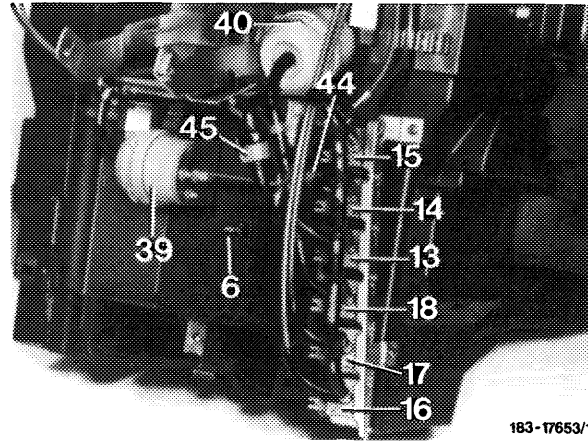

183-17653/1

The vacuum elements (38 to 43) for air flaps in air conditioning unit are activated with vacuum by the electric switchover valves (13 to 18).

All switchover valves (13 to 18) are generally open for passage when energized and are directly activating all vacuum elements.

Layout of vacuum element for scoop air flap and ETR-switch

- 29 ETR-switch
- 41 Vacuum element scoop air flap

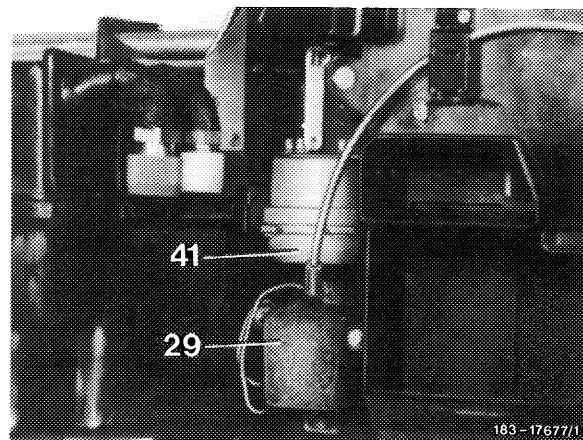

183-17677/1

Layout of vacuum elements for fresh air-recirculated air flap and main air flap

- 19 Electronic switchgear for blower control
- 38 Vacuum element defroster nozzle flaps
- 40 Vacuum element center nozzle flap
- 42 Vacuum element for fresh air-recirculated air flap and main air flap
- 43 Vacuum element for fresh air-recirculated air flap and main air flap

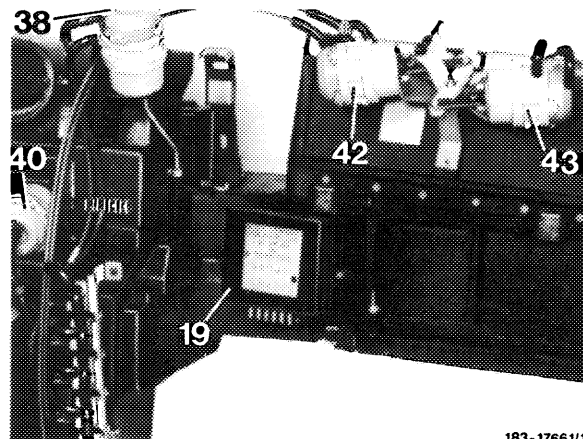

183-17661/1

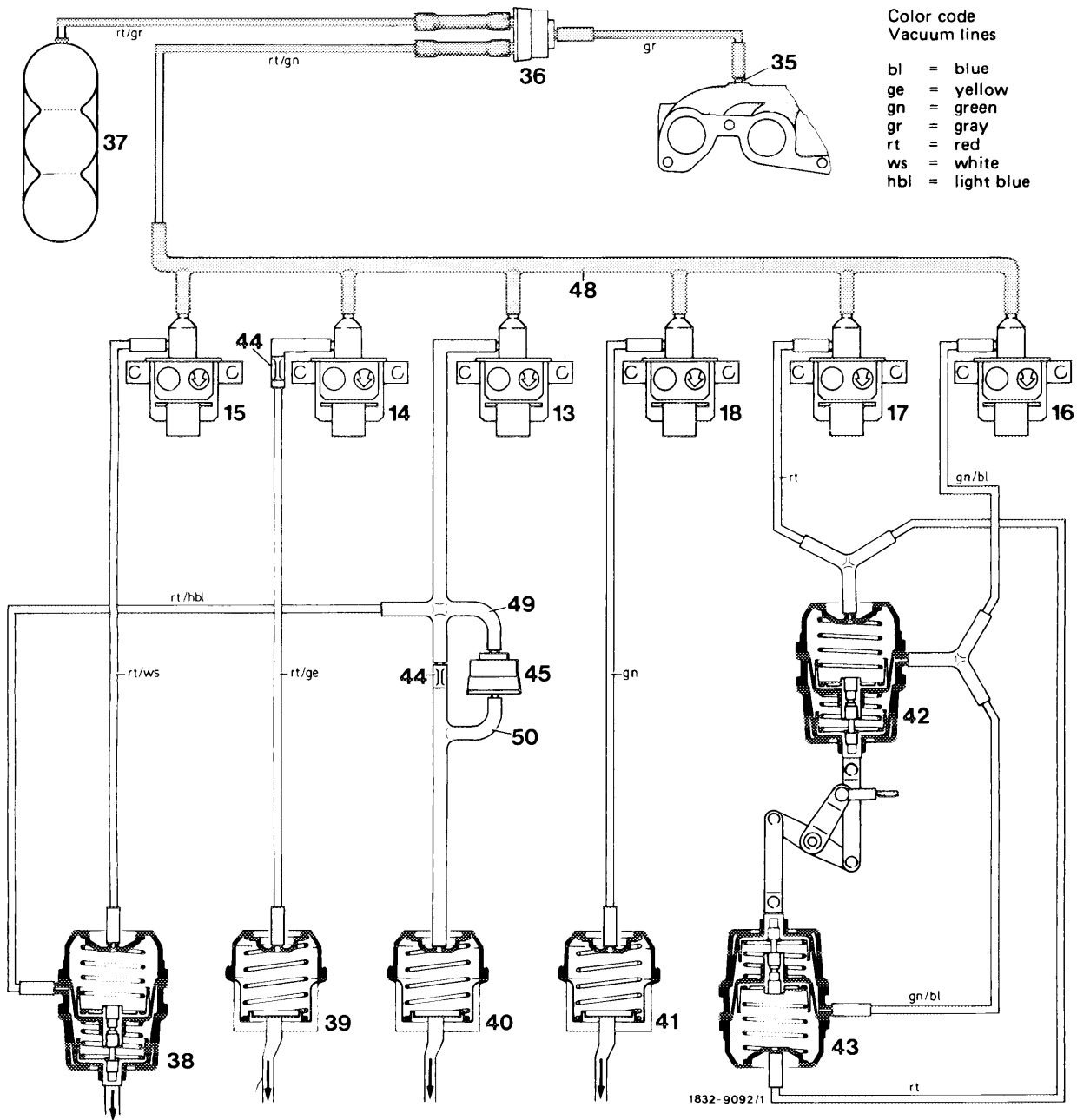

Vacuum function diagram automatic climate control, function selection "a" (defrosting)

- |                                                                                                                                                                                                                                                                                                                                                                                                                                                                                                                                                                                                                                                                                                                                          |                                                                                                                                                                                                                                                                                                                                                                                                                                                                                                                                                                    |
|------------------------------------------------------------------------------------------------------------------------------------------------------------------------------------------------------------------------------------------------------------------------------------------------------------------------------------------------------------------------------------------------------------------------------------------------------------------------------------------------------------------------------------------------------------------------------------------------------------------------------------------------------------------------------------------------------------------------------------------|--------------------------------------------------------------------------------------------------------------------------------------------------------------------------------------------------------------------------------------------------------------------------------------------------------------------------------------------------------------------------------------------------------------------------------------------------------------------------------------------------------------------------------------------------------------------|
| <ul style="list-style-type: none"> <li>13 Switchover valve for center nozzle flap</li> <li>14 Switchover valve for leg room flaps</li> <li>15 Switchover valve for defroster nozzle flaps</li> <li>16 Switchover valve for vacuum elements of fresh air-recirculated air flap and main air flap (small stroke)</li> <li>17 Switchover valve for vacuum elements of fresh air-recirculated air flap and main air flap (large stroke)</li> <li>18 Switchover valve for scoop air flap</li> <li>35 Vacuum connection on intake manifold</li> <li>36 Check valve</li> <li>37 Vacuum reservoir</li> <li>38 Vacuum element for defroster nozzle flaps (flaps "open")</li> <li>39 Vacuum element for leg room flaps (flaps "closed")</li> </ul> | <ul style="list-style-type: none"> <li>40 Vacuum element for center nozzle flap (flap "closed")</li> <li>41 Vacuum element for scoop air flap (flap "closed")</li> <li>42 Vacuum element for fresh air-recirculated air flap and main air flap (flap "open", 100 % fresh air supply)</li> <li>43 Vacuum element for fresh air-recirculated air flap and main air flap (flap "open", 100 % fresh air supply)</li> <li>44 Orifice</li> <li>45 Check valve</li> <li>48 7-point distributor</li> <li>49 4-point distributor</li> <li>50 3-point distributor</li> </ul> |
|------------------------------------------------------------------------------------------------------------------------------------------------------------------------------------------------------------------------------------------------------------------------------------------------------------------------------------------------------------------------------------------------------------------------------------------------------------------------------------------------------------------------------------------------------------------------------------------------------------------------------------------------------------------------------------------------------------------------------------------|--------------------------------------------------------------------------------------------------------------------------------------------------------------------------------------------------------------------------------------------------------------------------------------------------------------------------------------------------------------------------------------------------------------------------------------------------------------------------------------------------------------------------------------------------------------------|